

TAPER SHANK COUNTERSINKS WITH POINT ANGLE 120°, HSS

APPLICATION

Sinking pan-head screw taper holes, chamfering and deburring holes in steel, steel casting - alloyed and unalloyed, grey cast iron and malleable cast iron, light and non-ferrous metals, synthetics etc.

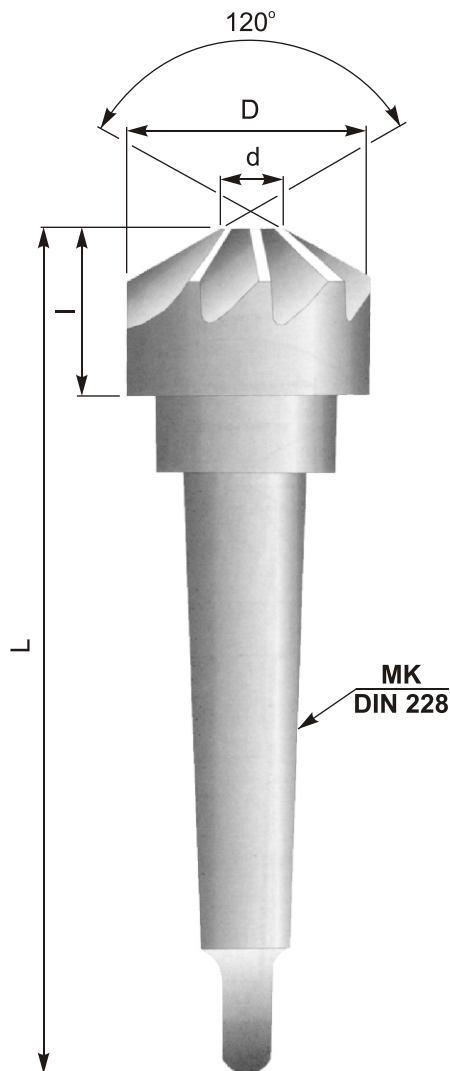

TECHNICAL DATA

Material	HSS (1.3343)			
Sinking angle	120°			
Hand of cut	Right			
Overall dimensions, mm				
D	d	L	l	MK
16	3,2	93	20	1
20	4,0	116	24	2
25	7,0	121	29	2
31,5	9,0	124	32	2
40	12,5	150	35	3
50	16,0	153	38	3
63	20	185	43	4
80	25	196	54	4